

SIMPLE TO VIEW AND DETERMINE

Alarms

The CANAIRE control system uses dual alarm system with two levels of signals:

- ALARM (“RED” alarm)
- WARNING (“YELLOW” alarm)

When any RED alarm appears in system:

- Alarm icon SERVICE KEY shows on display.
- Alarm acoustic signal sounds – long beep and then short beeps repeatedly.
- Arrange repair IMMEDIATELY.

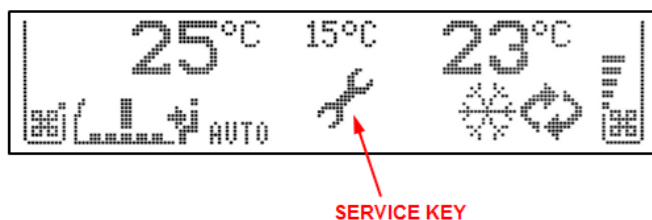

Any RED alarm will switch HVAC unit to the VENTILATION mode with automatic blower speed. The driver can change the blower speed manually. The compressor and condenser fans are stopped.

When any YELLOW alarm appears in system:

- Warning TRIANGLE shows on display.
- Warning acoustic signal sounds (one long beep).
- Arrange repair as soon as possible.

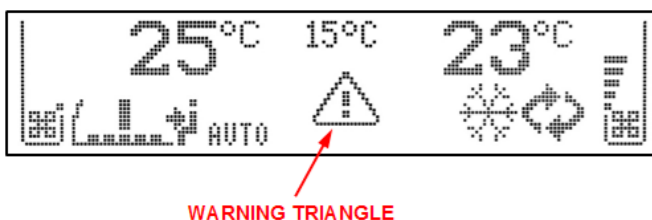

Alarm codes are stored in the memory to identify possible fault conditions. The alarm records can be displayed on the driver panel by press long of button **F** (3 s).

Alarm symbols can be removed by restart of control system (use the ON/OFF key to switch OFF, wait for 2 seconds, and then switch ON). After restart, the alarm symbol can appear again, if the reason for alarm still exists. If the alarm comes up again, don't restart the unit repeatedly, this will be of no benefit. Contact the service or Thermo King immediately.

SIMPLE TO SELECT

Setup

Start		Press the 3 buttons AUTO Driver and AUTO Passenger and SMOG for 3 seconds to enter Main Menu.
Menu		Press buttons with ventilator symbol on RIGHT SIDE repeatedly to scroll through function menu (UP and DOWN function).
Select	F	To select required item (folder, sub-menu) press F button (ENTER function).
Upper level		Press AUTO button to go back to upper menu level (ESC function).
Change		To change value for selected (highlighted) item press upper or lower button with ventilator symbol on LEFT SIDE repeatedly.
Next		Select next item with upper or lower button with ventilator symbol on RIGHT SIDE. (LEFT and RIGHT function).
Finish		Press ON/OFF button shortly.

In Setup mode operator can escape Setup menu every time by pressing ON/OFF key. No changes will be applied. When any function is selected and any value is changed the change is saved to the memory in the same time.

When the ignition is switched OFF, display shows date and time for next 12 seconds. If preheater timer is ON, timer icon will be also visible for this period.

If driver panel is ON during Preheater Time, then no action is executed, preheater will not start automatically.

SIMPLE TO VIEW AND DETERMINE

Display

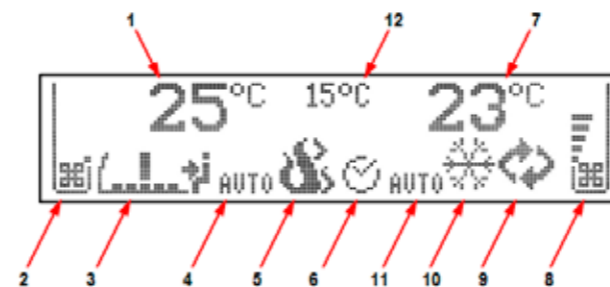

1	Driver's area temperature set point*
2	Driver's area – airflow indicator (Front Box blower speed)
3	Air flow direction (air distribution damper position) indicator
4	Automatic mode of Front Box icon
5	Preheater icon
6	Preheater timer icon
7	Passenger's area temperature set point*
8	Passenger's area – airflow indicator (HVAC unit blower's speed)
9	SMOG icon
10	HVAC unit operating mode icon
11	Automatic mode of HVAC unit icon
12	Ambient temperature*

* Depends on system configuration, driver panel or CANAIRE system setting.

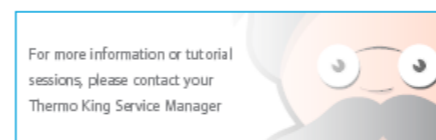

CANAIRE Driver Panel

Drivers Guide to Simple Operation

SIMPLE TO START

Description

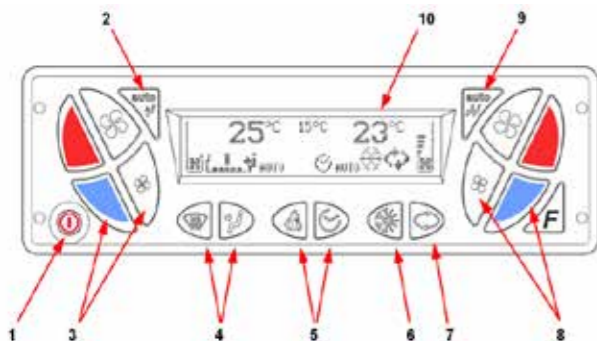

1	ON/OFF button Two possibilities when panel is powered: Welcome screen with actual date and time ▶ driver panel is powered but out of operation ▶ To start press ON/OFF button. • Standard operating screen.
2	Automatic control of required temperature** – driver's area
3	Driver's area temperature and air flow setting** • Set higher temperature: press RED button • Set lower temperature press BLUE button**. • To set higher airflow for windscreen / driver's area press button with big fan, for less airflow press button with small fan.
4	Air flow direction (Air distribution damper position) • To change air flow direction between windscreen and driver or to start defrost function.
5	Preheater control buttons
6	HVAC operating mode button • To change HVAC unit operating mode press button repeatedly.
7	SMOG button • To close both HVAC unit and Front Box fresh air dampers press this button. • SMOG mode is terminated automatically after pre-set period. • To cancel press SMOG button again.
8	Passenger's area temperature and air flow setting • To set higher temperature press RED button, for lower temperature press BLUE button. • To set higher airflow press button with big fan, for less airflow press button with small fan.
9	Automatic control of required temperature – passenger's area
10	LCD graphic display

SIMPLE TO SET

Preheater control

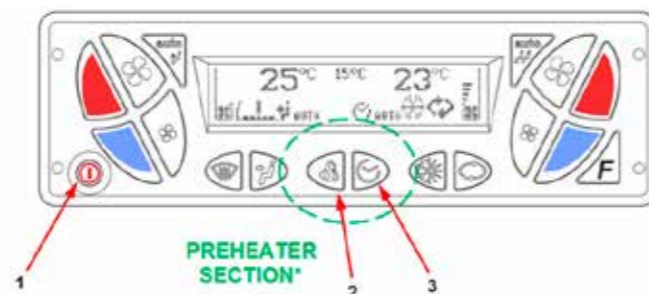

1	ON/OFF button
2	 • Press for immediate start of preheater. • Press again to stop preheater operation.
3	PREHEATER TIMER button Press short – activate the timer. Press long (more than 3 seconds) – setting of Preheater Wake Up time: Change ▶ HOURS Press upper or lower button with fan symbol on LEFT SIDE repeatedly. Next step ▶ MINUTES • Press lower button with fan symbol on RIGHT SIDE. Change ▶ MINUTES Press upper or lower button with fan symbol on LEFT SIDE repeatedly. Next step ▶ WORKING DAYS Press lower button with fan symbol on RIGHT SIDE. Change ▶ DAY Press upper or lower button with fan symbol on LEFT SIDE as necessary. Selected working day is underlined. Repeat steps 4 and 5 for every day. Finish Press ON/OFF button shortly or Auto passenger's area button.

SIMPLE TO OPERATE

Driver's area climate control

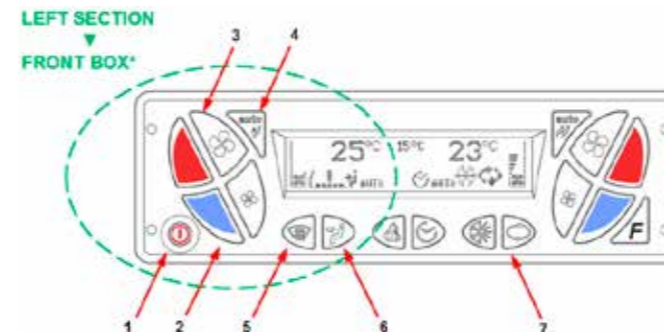

1	ON/OFF button
2	Driver's area temperature setting** RED – higher temperature is required BLUE – lower temperature is required NOTE: Press Left RED or blue button for 3 seconds to set permanent heating or cooling of Front Box (whichever is required). Display will show Hi or Lo for driver's area. Press Left RED or BLUE button to cancel this function.
3	Manual air flow setting (air distribution blower speed) BIG fan – more airflow SMALL fan – less airflow
4	Automatic control of required temperature** – driver's area
5	Air flow direction (air distribution damper position) setting Press short – air to windscreen Press long – DEFROST/DEMIST function
6	Air to driver's seat
7	SMOG button To close both HVAC unit and Front Box* fresh air dampers press button. The SMOG mode is terminated automatically after pre-set period of time or press SMOG button again to cancel.

* Depends on system configuration.

** The compressor is always controlled by HVAC unit. If the cooling function is required by Front Box only, the compressor doesn't start.

SIMPLE TO OPERATE

Passenger's area climate control

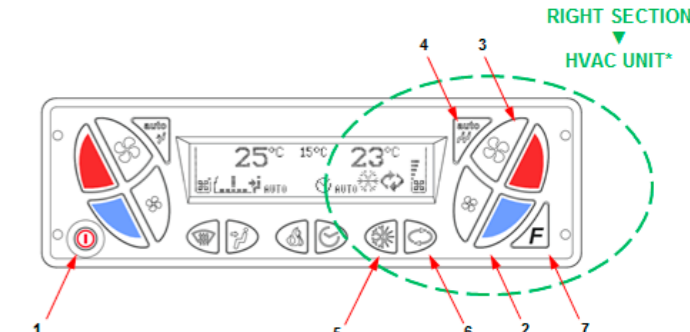

1	ON/OFF button
2	Passenger's area temperature setting RED – higher temperature is required BLUE – lower temperature is required
3	Manual air flow setting (HVAC unit blowers speed) BIG fan – more airflow SMALL fan – less airflow
4	Automatic control of required temperature – passenger's area
5	HVAC unit operating mode Ventilation Heating* Cooling* AUTO mode* Reheat* (TWO DROPS symbol – if available and configured)
6	SMOG button To close both HVAC unit and Front Box* fresh air dampers press button. The SMOG mode is terminated automatically after pre-set period of time or press SMOG button again to cancel.
7	F button*