

A microprocessor based controller,
designed for small HVAC units.

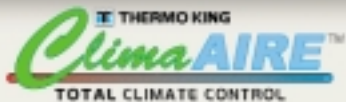

Designed for Small and Mid-size Buses

- Simple & easy to operate
- Four working modes: vent, cool, heat & auto
- Blower speed control
- Fresh air damper control
- Coil freeze protection
- Compressor cycling monitor
- Alarm display



ClimaAIRE™ Control System Specifications

OUTPUTS

- Number of outputs - 7 max. 700mA
- 3 for blower speed (0/1 or PWH-High Output)
- Compressor Clutch
- Boost Pump
- Solenoid Heat Valve (PWM)
- Fresh Air Damper (0/1)

INPUTS

- Interior Temperature Sensor
- Freeze Temperature Sensor
- Ambient Temperature Sensor - Switch
- Pressure Sensor - Switch (LPCO,HPCO)

POWER SUPPLY

- 10-35V DC max. 100m amps
- Operating Temperature:
-30°C - 80°C

APPLICATION

- Ready for HVAC unit
- Setup Temperature
17°C - 27°C
- Connection by Molex 39-01-2140

DIMENSIONS millimeters (inches)

Width 152 mm (6.00")
Height 57 mm (2.24")
Depth 60 mm (2.36")

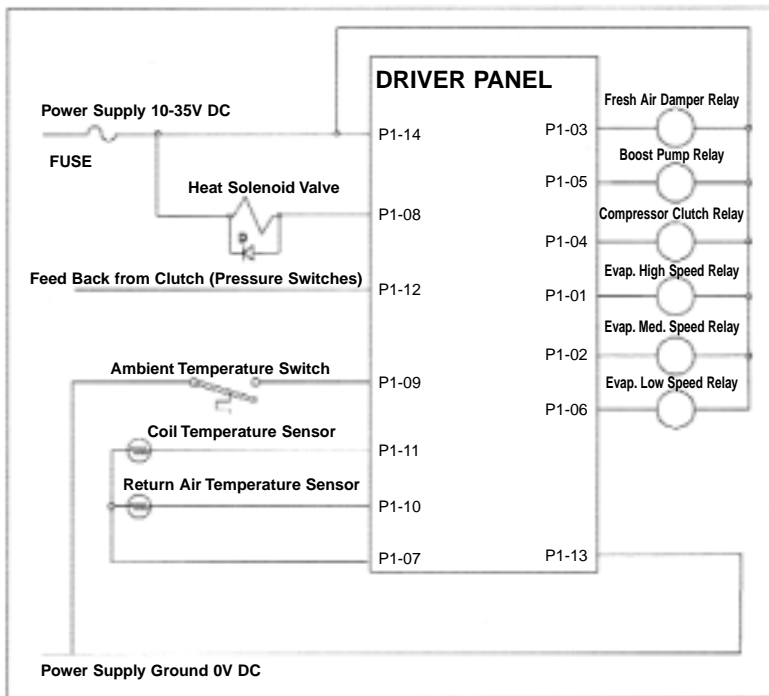

Worldwide Service Organization

Thermo King backs its equipment and customers with a highly-trained, worldwide service organization. This assures you the support of factory authorized service facilities and a stock of factory parts and factory trained mechanics.

Warranty Summary

Terms of the Thermo King Limited Express Warranty are available upon request.

Basic unit is warranted to be free from defects in material and workmanship for a period of one year from date in service. Warranty covers parts and labor only.

Manufacturer is not responsible and will not be held liable in contract or tort (including negligence) for any special, indirect or consequential damages including, but not limited to, injury or damage caused to vehicles, contents or persons, by reason of the installation or use of any Thermo King product or its mechanical failure.

Thermo King
World Headquarters
Minneapolis, MN U.S.A.
Tel: 1 952 887 2200
Fax: 1 952 887 2529

Thermo King
Asia Pacific
Hong Kong, PRC
Tel: 852 2507 9100
Fax: 852 2827 5159

Thermo King
do Brasil
Campinas, Brasil
Tel: 55 19 745 6400
Fax: 55 19 245 1106

Thermo King
Europe
Galway, Ireland
Tel: 353 91 751 231
Fax: 353 91 751 911

Thermo King
Europe
Kolin, Czech Republic
Tel: 420 321 757111
Fax: 420 321 757170

Specifications are subject to change without notice.

Thermo King Corporation Ingersoll-Rand Company

www.thermoking.com

Monivea Road, Mervue,
Galway, Ireland.

Zoning Zaventem Zuid, Mercuriusstraat 24,
B-1930 Zaventem, Brussels, Belgium.

